

# REED REPLACEMENT INSTRUCTIONS

FOR ALL VFORCE3/3i AND VFORCE4/4R/4X APPLICATIONS

We strongly recommend you read through the following instructions completely before beginning the installation. If any part of the information below is unclear to you, do not proceed with installation. Instead please contact us with any questions or ask a qualified mechanic to assist you.



## IMPORTANT: PLEASE READ BELOW FIRST

If your replacement reed petals came with the below sticker on the package, follow these directions.



### ATTENTION:

Reed petals must be installed as specified by the enclosed instructions or it will result in premature petal wear.

When replacing reed petals, the curved side of the petal must face towards the reed cage for both the outer and inner reed petals. Failure to do so may result in premature reed petal wear.

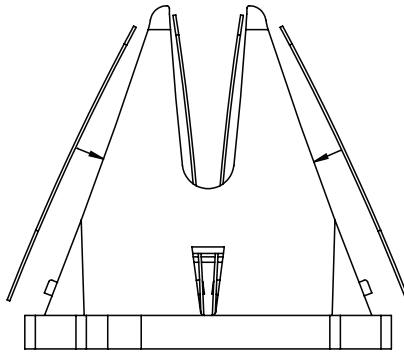

## HAVE QUESTIONS?

We can't wait to help!  
frontdesk@mototassinari.com  
(603) 298-6646 M-F 8am-5pm EST

Helpdesk with FAQ's

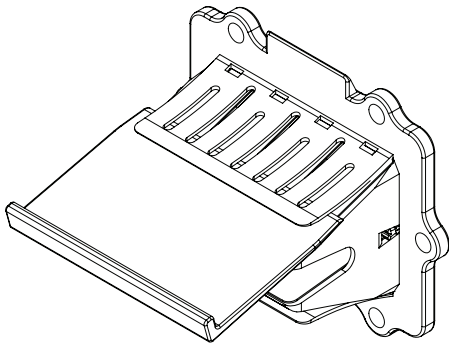
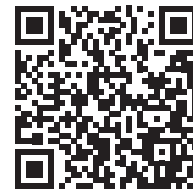

**Step 1a)** For reed valves with extended reed stops, insert included tool between reed petal and reed stop and push cage firmly.



**Step 1b)** For reed valves with short reed stops, no tool is needed, push cage firmly through manifold as shown.

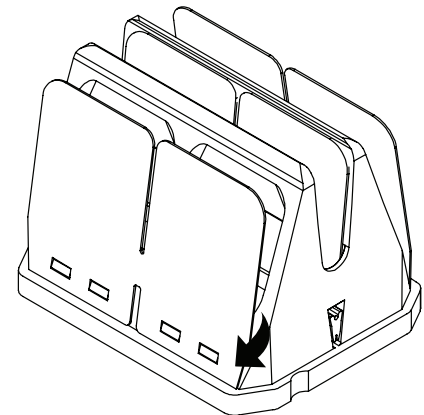

**Step 2)** Remove old reed petals from locating tabs.

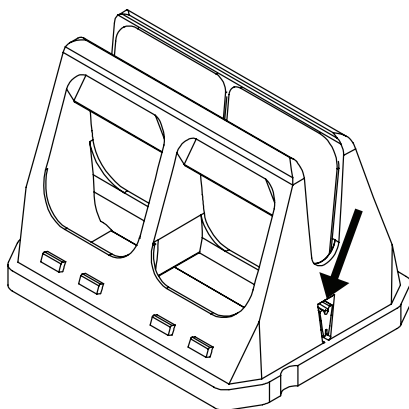

**Step 3)** To remove center reed petals, place small screwdriver into slot above retainer bar at a 45 degree angle.

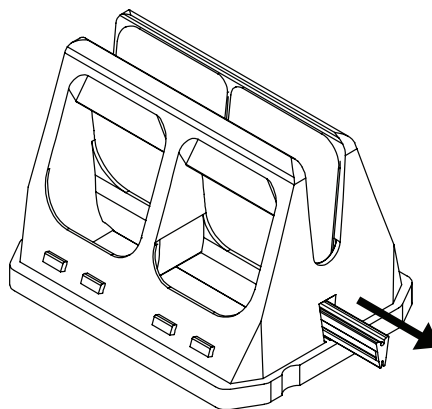

**Step 4)** Using light pressure pry retaining bar out gradually until retaining bar can easily be removed by hand.

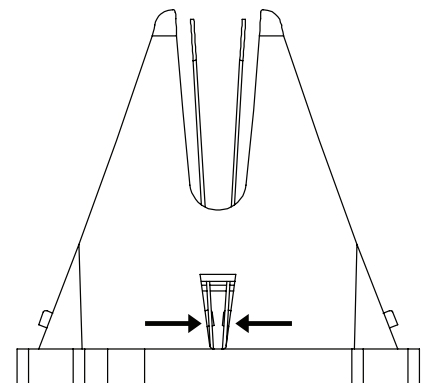

**Step 5)** With retaining bars removed, push reed petals free of locating tabs. Reed petals can now be removed.

# REED REPLACEMENT INSTRUCTIONS

FOR ALL VFORCE3/3i AND VFORCE4/4R/4X APPLICATIONS

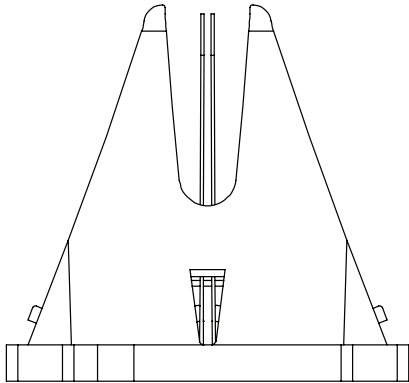
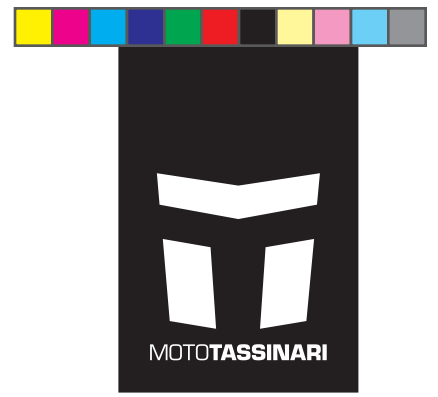

**Step 6)** Place two reed petals in center of reed cage, making sure they are at the bottom.

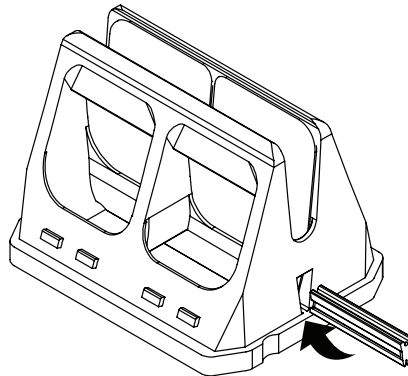

**Step 7)** Separate reed petals and place new retaining bar (supplied) on an upward angle making sure it fits between the reed petals.

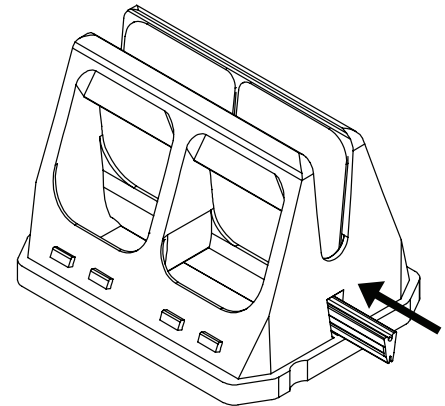

**Step 8)** Now slide bar in parallel to reed cage base, making sure to engage reed locating tabs.

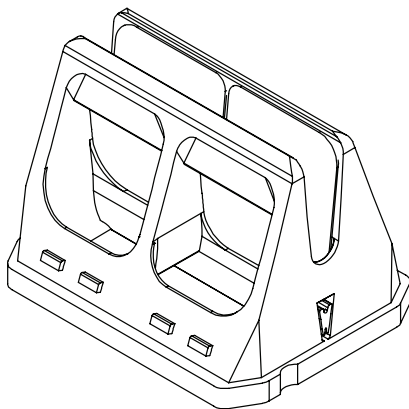

**Step 9)** Using a screwdriver or similar tool, push retainer bar flush with reed cage surface.



**Step 10)** Place reed petals on outside surface and press on to locating tabs.

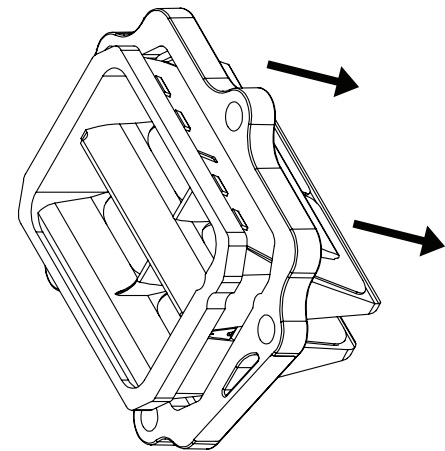

**Step 11)** With reed petals in place, push reed cage through flange until locating tabs snap into their openings.

## COMMON QUESTIONS...

**When I hold the reed valve up to a light source I can see what look like pin holes in the reed petals. Should I be concerned?**

Absolutely not. There are multiple plies of carbon fiber weave in a reed petal. In some sheets of carbon that we cut the reeds from, there are sections where the fiber weave lines up, and makes it look like you have pin holes. However the area is structurally sound as there is clear epoxy resin covering the entire reed petal surface.

**Should I be able to see any light through the sides of my VForce4 reed valve system?**

It is typical to see a sliver of light visible on the sides of a brand new VForce4 assembly or after installing new reed petals. This is unavoidable due to the design which incorporates a concave

surface that preloads the reed tip. The VForce4 also uses a curved petal which along with the concave reed cage surface further work to preload the reed tip. After initial use, this sliver of light typically disappears as the reeds break-in and become seated. This has absolutely zero impact on performance.

**How often do I need to change the reed petals?**

Please remember reed petals are a wear item, meaning they wear out over time and become less effective. We suggest inspecting the reed petals at a minimum of once a season. In higher wear uses such a super-minis, high-horsepower/modified engines, high rpm applications etc., we suggest inspecting them more often. Signs of wear will be possible chipping and or fraying at the reed tips and corners.