

# VFORCE INSTALLATION INSTRUCTIONS

## FOR ALL VFORCE3/3i AND VFORCE4/4R/4X APPLICATIONS

We strongly recommend you read through the following instructions completely before beginning the installation. If any part of the information below is unclear to you, do not proceed with installation. Instead please contact us with any questions or ask a qualified mechanic to assist you.



**CAUTION:** Refer to your owner's service manual for detailed instructions and illustrations for proper removal of the carburetor, intake manifold and stock reed cage.

- 1) Remove your stock reed cage assembly.
- 2) The following procedure is not necessary for most applications. If however, your rubber intake manifold has tabs that extend into the reed cage (see **Figure 1**), they must be removed. Please use your desired cutting implement to cleanly cut the tabs off flush at the base (see **Figure 2**).
- 3) Assemble using your new VFORCE reed valve(s) and modified (if necessary) stock manifold with supplied gaskets. Torque manifold bolts to the factory recommended specifications.
- 4) After installation is complete, take time to check and make sure everything is tight. Inspect all fuel and vent lines to be sure they are routed properly and free of damage and kinks.

**Figure 1: Before**

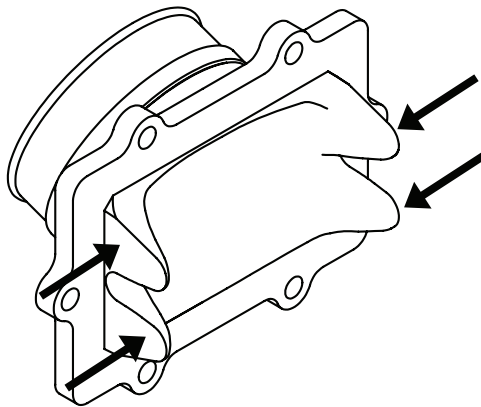

**Figure 2: After**

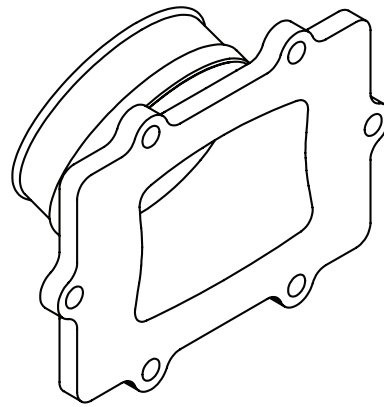

## COMMON QUESTIONS...

**When I hold the reed valve up to a light source I can see what look like pin holes in the reed petals. Should I be concerned?**

Absolutely not. There are multiple plies of carbon fiber weave in a reed petal. In some sheets of carbon that we cut the reeds from, there are sections where the fiber weave lines up, and makes it look like you have pin holes. However the area is structurally sound as there is clear epoxy resin covering the entire reed petal surface.

**When I hold my VFORCE reed valve up to a light source, I can see light coming through the reed tips. Should I be concerned?**

The short answer is, "No, absolutely not". However let's take

it further and give you the specifics of why you should not be concerned and why this is not a sign of poor quality nor going to hinder engine performance in any way.

Worth noting is, at 8,000 RPM the reed petals are opening and closing more than 133 times every second. At this frequency the reed petals are not so much opening and closing as they are vibrating.

This is where the uniqueness of the VFORCE design really shines against the stock reed valve and our competitors. As you may notice when looking at the VFORCE reed valve system, the reed petals are at much less of an angle than the reed petals on a

# VFORCE INSTALLATION INSTRUCTIONS

FOR ALL VFORCE3/3i AND VFORCE4/4R/4X APPLICATIONS



## COMMON QUESTIONS (continued)

conventional style reed valve. The result of this design is reed petals that are able to flex less, yet open further to create better airflow with less wear on the reed petals.

However also because of this design, it is sometimes possible to see light through the reed tips. This is especially true for the inside petals. Keep in mind when looking into the reed valve from the intake side you are looking directly down the surface of the inside petals. This is impossible to do on conventional reed valve designs due to their use of only two reed petal surfaces as opposed to four on the VFORCE reed valve.

Can we manufacture a VFORCE reed valve that would prevent any light at the reed tips? Certainly, but that would require a stiffer, higher tension reed petal and/or placing more pressure at the reed tips, which we're not willing to do as it would sacrifice performance. There are other factors at play in regards to reed petals sealing during use, such as back pressure and the fuel mix pooling at the reed tips between the reed petal tip and the reed cage.

So now that you understand why the gap is there, what exactly is an "acceptable gap"? If you can slide a piece of paper into the gap, that is perfectly acceptable. However if you can slide a credit card into the gap, that is unacceptable and we ask that you please contact us.

We've supplied many of the top teams such as the factory Honda, Kawasaki, KTM, Suzuki, Yamaha, Arctic Cat, Polaris and Ski-Doo race teams and they've all run the same exact "off the shelf" product that is available to our customers. If there was a negative performance effect from using the VFORCE reed valve design, they haven't found it.

### **Should I be able to see any light through the sides of my VFORCE4 reed valve system?**

It is typical to see a sliver of light visible on the sides of a brand new VFORCE4 assembly. This is unavoidable due to the design which incorporates a concave surface that preloads the reed tip. The VFORCE4 also uses a curved petal which along with the concave reed cage surface further work to preload the reed tip. After use, this sliver of light typically disappears as the reeds break-in and become seated. This has absolutely zero impact on performance.

### **Should I be able to see any light at the reed tips or through the sides of my VFORCE4R?**

All VFORCE4R should seal completely at the reed tip. However there will always be a sliver of light visible on the sides of a brand new assembly. This is unavoidable due to the design which incorporates a concave surface that preloads the reed tip.

After use, this sliver of light typically disappears as the reeds break-in and become seated. This has absolutely zero impact on performance.

### **Will I need to rejet after installing the VFORCE reed valve system?**

If your snowmobile/motorcycle/atv/pwc/etc., was running well prior to installation, typically there is no need to make adjustments. However if adjustments are necessary, it's usually a minor adjustment of the air screw.

### **Will I ever need to change the reed petals?**

Most likely. Please remember reed petals are a wear item, meaning they wear out over time and become less effective. We suggest inspecting the reed petals at a minimum of once a season. In higher wear uses such a super-minis, high horsepower/modified engines, high-rpm applications, etc. we suggest inspecting them more often. Signs of wear will be possible chipping and/or fraying at the reed tips and corners.

### **Is the VFORCE compatible with EFI, TBI, TPI, etc. systems?**

Yes. The VFORCE reed valve system is compatible with EFI and no further modifications are needed for EFI systems as the VFORCE is virtually Plug and Play.

### **Can you make a custom VFORCE for my "X"?**

Unfortunately no. Moto Tassinari does not offer any custom reed valve design as we focus all our time and energy on constantly improving and expanding our current product lines.

## HAVE QUESTIONS?

We can't wait to help!

frontdesk@mototassinari.com  
(603) 298-6646 M-F 8am-5pm EST

Helpdesk with FAQ's

